

seepex.com
all things flow

Here is your conveying solution:
Product group W.

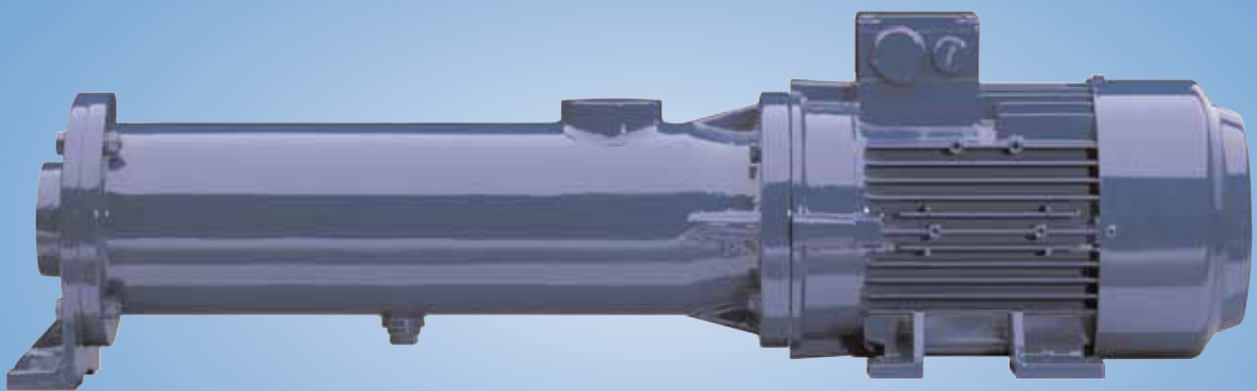

W – Wobble pumps

Pumps of product group W can be used in almost all industries. They are designed to handle liquids of all viscosities and even products with high solids contents. They are cost effective, portable and versatile.

Joint connection

consisting of just 5 components. Power transmission through wear resistant, hardened and replaceable joint parts, easily repaired.

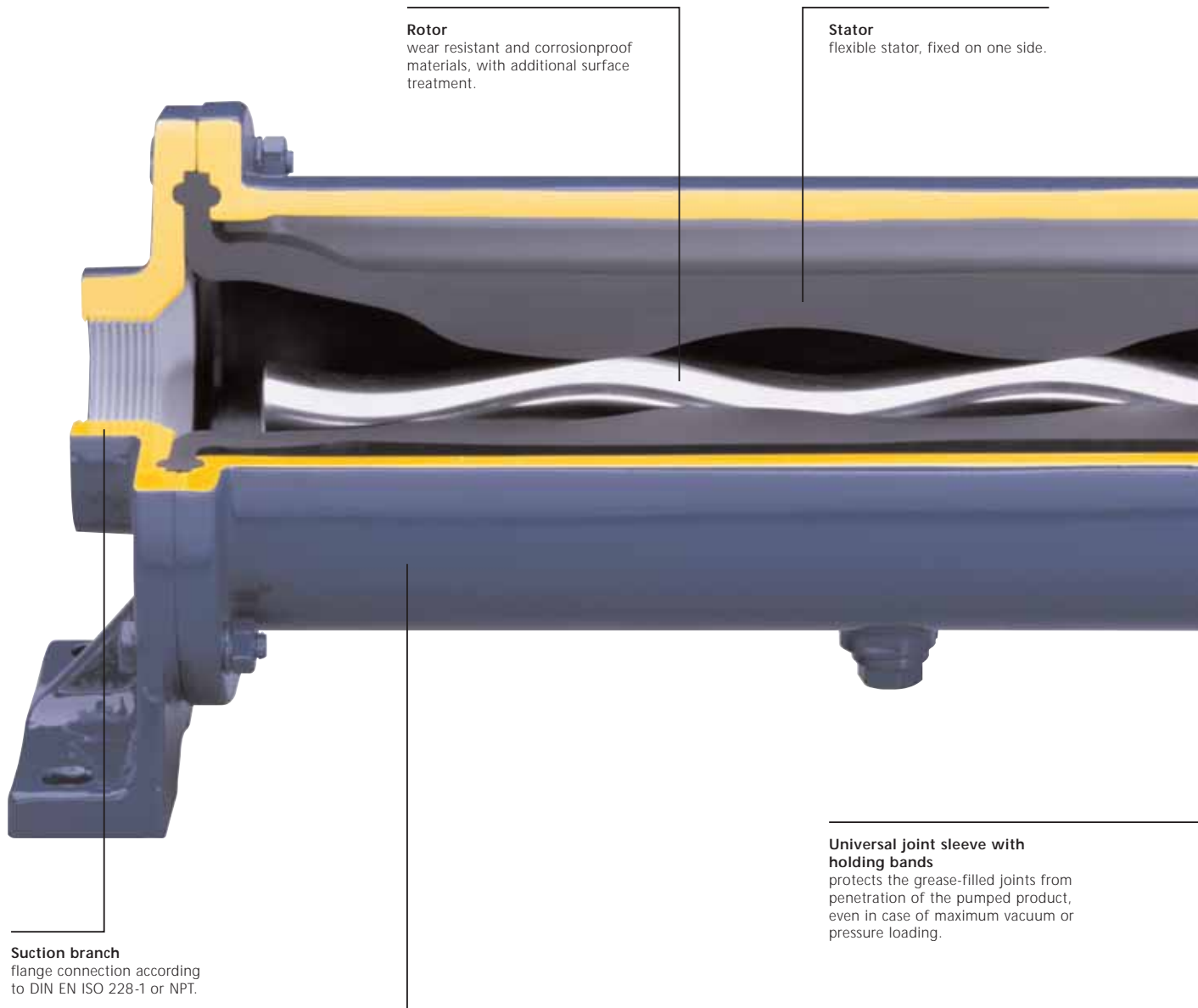

Rotor

wear resistant and corrosionproof materials, with additional surface treatment.

Stator

flexible stator, fixed on one side.

Suction branch

flange connection according to DIN EN ISO 228-1 or NPT.

Pressure casing

with drain plug and connections for pressure/vacuum gauge. Flange connections according to DIN EN ISO 228-1 or NPT, can be rotated in 90° increments.

Universal joint sleeve with holding bands

protects the grease-filled joints from penetration of the pumped product, even in case of maximum vacuum or pressure loading.

Shaft sealing
single-acting mechanical seal,
located inside the pumped product.

Shaft sealing retainer
for retaining the mechanical seal
and for centring of the drive.

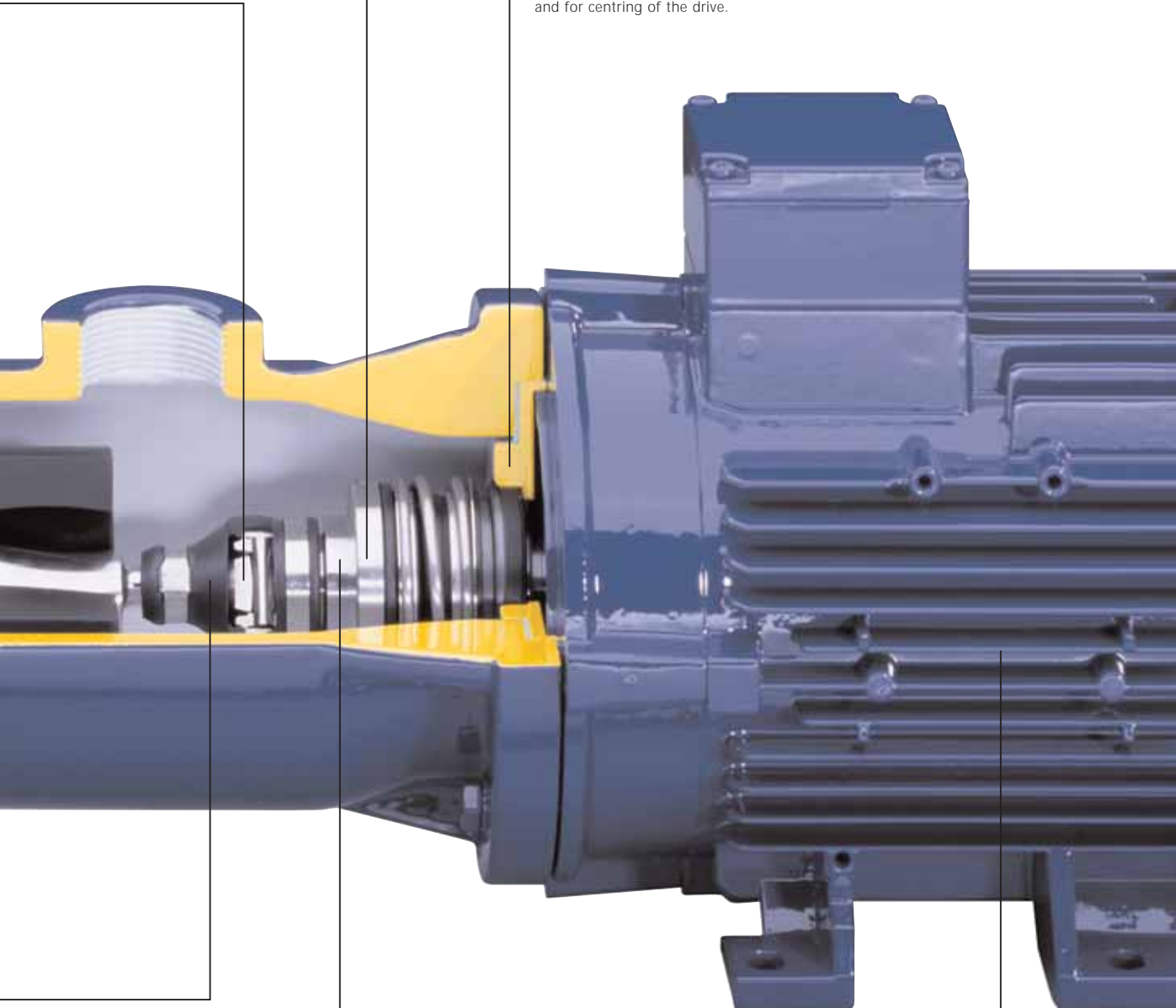

Plug-in shaft
connects the drive shaft to the
joint; upon request.

Drive
electric motor, directly flanged to the pump
without additional couplings or guards, upon
request geared motor or variable speed drive
available.

Why wobble pumps?

Because they are used in applications such as agriculture, ceramics, chemical and biochemical industry, construction, dyeing and varnishing, electroplating, environment technology, fish industry, food and beverage industry, mining, non-metallic minerals, oil production and offshore technology, petrochemicals, pharmaceutical and cosmetics industry, pulp and paper industry, shipbuilding, sugar industry, supply and waste disposal industry, textile industry, vehicle construction and equipment and wood processing industry.

Features

- Service-friendly and economical due to simple pump construction
 - Rapid exchange of conveying elements due to rotating unit with only one joint
 - Space-saving due to short, compact design with directly flanged drive (block design)
- > Conveying capacity: up to 10 m³/h (45 GPM),
Pressure: up to 4 bar (60 psi)

Overview of ranges

Pumps of the BW range are very easy to handle and economical. In contrast to conventional progressive cavity pumps, they have only one joint, which saves costs and reduces downtime when replacing spare parts. The wobble-stator pump is also space saving because the lantern has been dispensed with – the drive is flanged onto the pump directly.

Range BW

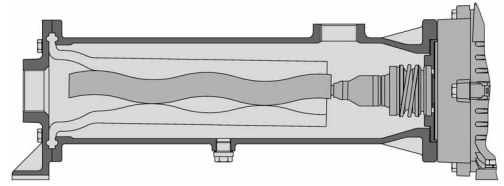

seepex.com
all things flow

And what can we get flowing for you? Your nearest contact:

Hyxo Oy

P.O. Box 16 (Palokorvenkatu 2)
FI-04261 Kerava, Finland
Tel. +358 10 417 4500
Fax +358 10 417 4501
hyxo@hyxo.fi • www.hyxo.com

Or visit www.seepex.com