

ZX 411.3 - serie

robust, durable, versatile, economic...

sera - diaphragm pumps

of series ZXM 411.3 and ZXRI 411.3 are oscillating displacement pumps for delivery and dosing and feeding liquids in a variety of industries. Performance range between 2200 l/h and 3100 l/h, pressures up to max. 4 bar.

Application

Liquid chemicals with aggressive, odorous, abrasive, radioactive, flammable, viscous or toxic properties.

...further features of performance

- high dosing accuracy
- long service life of diaphragms*
- high-quality materials
- linear control characteristic (ZXRI series)
- low maintenance
- low operating expenses
- leakage-free
- unlimitedly to run dry
- easy to operate
- designs according to ATEX
- great suction heights

* compared to common conventional diaphragms

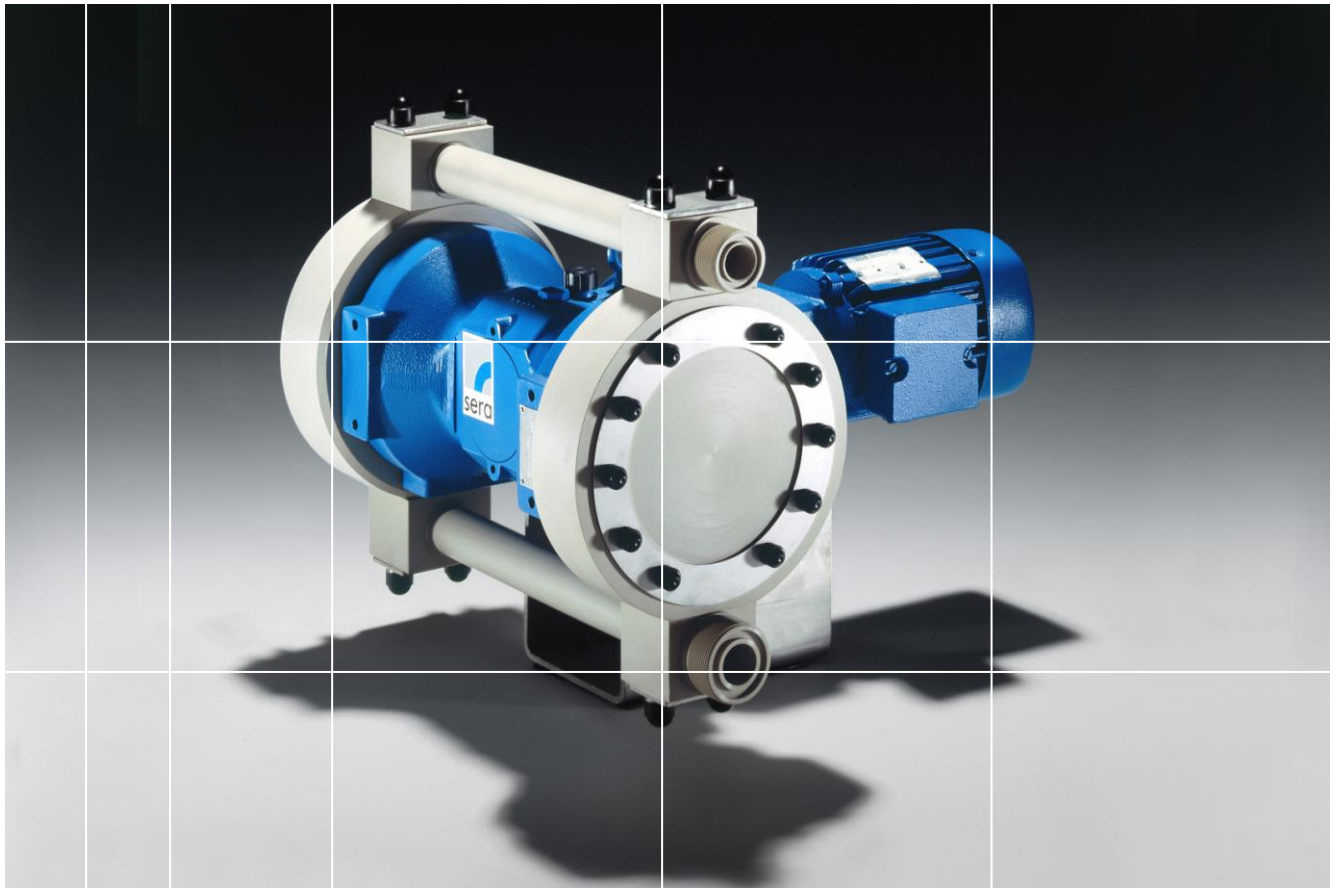

Design options

The pump has two heads – technical data according to the performance schedule.
The capacity of the ZXRI - type series can be set manually at the integrated frequency converter.
The ZXM-types run with constant stroke frequency. Therefore the capacity cannot be set. In ZXRF design they can be controlled via an external frequency converter so that their capacity can be adjusted to the process conditions again.

Single diaphragm pump *

The mechanically coupled working diaphragm acts directly upon the chemical.

* Double diaphragm design on request

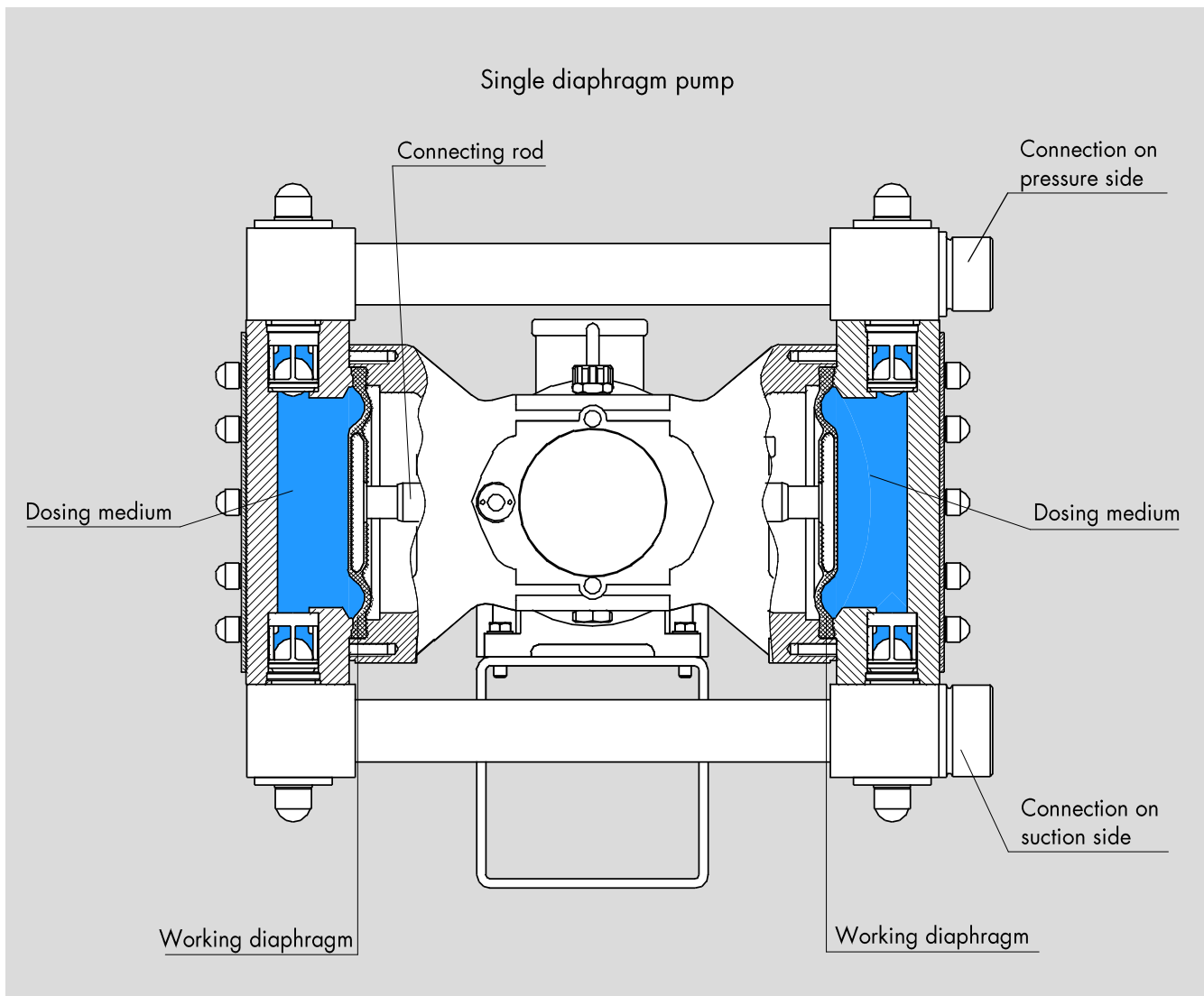

Technical Data

Serie ZXM 411.3

Pump type	Nominal capacity		Max. counter-pressure p_2 max. [bar]	Max. suction height [mWS]	Inlet size DN [mm]	Outlet size DN [mm]	Nominal stroke frequency		Driving power (motor) P_M [kW]
	Q_N 50 Hz [l/h]	Q_N 60 Hz [l/h]					n_N 50 Hz [min ⁻¹]	n_N 60 Hz [min ⁻¹]	
ZXM 411.3 – 2200 e	2200	2640	4	8	32	25	92	110	0,75
ZXM 411.3 – 2600 e	2600	3120	4	8	32	25	103	123	0,75
ZXM 411.3 – 3100 e	3100	¹⁾	4	8	32	25	128	–	0,75

¹⁾ with 60 Hz type ZXM 411.3 - 2600e is to be used

Serie ZXRI 411.3

Pump type	Nominal capacity Q_N 50 / 60 Hz [l/h]	Max. counter-pressure p_2 max. [bar]	Max. suction height [mWS]	Inlet size DN [mm]	Outlet size DN [mm]	Nominal stroke frequency n_N 50 / 60 Hz [min ⁻¹]	Driving power (motor) P_M [kW]
ZXRI 411.3 – 2600 e	230 – 2600	4	8	32	25	110	0,75
ZXRI 411.3 – 3100 e	230 – 3100	4	8	32	25	123	0,75

Materials

The high quality of the materials ensures continuous and reliable operation. We have the optimum material* for each requirement.

Pump body and valves:

PVC, PP, PVDF, 1.4571

Valve balls:

Glass, PTFE, 1.4401

Valve seals:

EPDM, FPM, FEP-covered

Working diaphragm:

PTFE-faced

* please ask us for any material required but not mentioned here

Drive

Each drive unit consists of a proven motor coupled to a stroke mechanism in a robust cast iron housing.

sera – cast iron housings can cope with even extreme operating conditions due to the thickness of the material and the surface treatment.

Control

The capacities of the sera – diaphragm pumps are constant or infinitely variable.

Manual capacity control via:

- Adjustment of the stroke frequency

Automatic capacity control, dependent on analogue or digital input signals via:

- Three-phase motors with frequency converters

Special designs

- Diaphragm rupture monitoring device
- Assembly of stroke frequency transmitter

Accessories

For the optimum installation of a dosing pump we can supply all the necessary accessories such as valves, pulsation dampers, injection fittings, dosing tanks, flow controllers, etc. against your order.

Local sera - Representative:

HYXO
P.O. Box 16 (Palokorvenkatu 2)
FI-04261 KERAVA, FINLAND
Telephone +358 10 417 4500
Fax +358 10 417 4501
www.hyxo.fi

Seybert & Rahier
GmbH + Co. Betriebs-KG
sera-Straße 1
34376 Immenhausen
Germany
Tel. +49 5673 999-00
Fax +49 5673 999-01
www.sera-web.com
info@sera-web.com