

PRODUCT INFORMATION

PROCESS ANALYSIS
ULTRATURB PLUS SC



The top-class IR turbidity sensor: ULTRATURB plus sc

- **Large measuring range**
0.0001 - 1.000 FNU
- **Permanent factory calibration**
- **Self-cleaning measuring chamber**
- **Can be combined as required with other SC probes**

The all-rounder for very low to medium turbidities

ULTRATURB plus sc is a precision bypass sensor; it is suitable for ultra-clear media to media with medium turbidity due to the particularly low level of light interference. In this way ULTRATURB plus sc facilitates optimal filtration management in municipal and industrial water treatment - from checks on untreated water to outlet monitoring. The measured data from one or several sensors are processed by the SC 100 or SC 1000 controller.

Low operating costs

The stable pulsed IR source in conjunction with the automatic cleaning guarantees stable measured values and high availability.

Minimum maintenance effort, straightforward operation and low investment costs contribute to the excellent overall economic profile of the instrument.



UNITED FOR WATER QUALITY

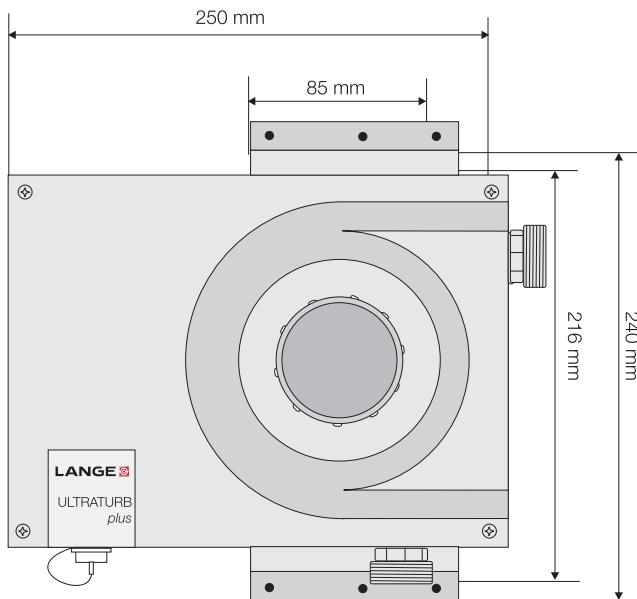

The dimensions of the ULTRATURB plus sc are 250 x 240 x 110 mm (W x H x D)

Technical data

Measuring technique	90° scattered light in accordance with DIN EN ISO 7027 infrared light 860 nm
Measuring range	0.0001–1000 FNU (TE/F, NTU, FTU) can be programmed as required (0.0001–250 EBC = 2500 ppm SiO ₂)
Resolution	0.0001–0.9999 / 1.000–9.999 / 10.00–99.99 / 100–1000 FNU
Precision	±0.008 FNU or ±1 % (0–10 FNU))
Reproducibility	±0.003 FNU or ±0.5 % (0–2 FNU)
Variation coefficient	1 % in accordance with DIN 38402
Response time	1–60 s can be programmed as required
Air bubble compensation	Physical-mathematical
Calibration	From the factory, permanent
Verification	With STABL CAL or dry standard CVM
Sample size required	Min. 0.2 l/min, max. 1 l/min, max. 6 bar (20°C)
Sample temperature	Max. 50 °C
Ambient temperature	Sensor: +2 °C to +40 °C, Display unit: -10 °C to +40 °C
Sample connection	Hose ID 13 mm or fixed connection with G+F system parts
Automatic cleaning	Cleaning with wiper
Materials	Measuring window: quartz; wiper profile: silicone; measuring chamber: Noryl, GFN2; housing: ASA; wiper axle: stainless steel 1.4571
Inspection interval	On request 1/year with HACH LANGE service contract with guarantee extension to 5 years
Enclosure rating	IP 65
User maintenance	0.5 h/month for ULTRATURB plus sc
Weight	Approx. 1.5 kg
Display unit	SC 100 Controller (model LXV401) or SC 1000 Controller (mod. LXV400 and LXV402)

Two variants: ULTRATURB

ULTRATURB sc and ULTRATURB plus sc comply with DIN EN ISO 7027 and are identical except for the special additional plus: on the ULTRATURB plus sc automatic cleaning with a wiper reliably prevents soiling of the measuring chamber as the soiling starts to build up - the guarantee for stable measured values even in the lowest measuring range.

HACH LANGE services



Orders, information and consultation without delay: Tel. 012 56 333 403



Support on-site by expert sales team.

Ordering information

DESCRIPTION	ART. NO.
ULTRATURB plus sc turbidity bypass sensor	
- with 0.35-m-cable	LPV415.99.10001
- with 5-m-cable	LPV415.99.20001
- with 10-m-cable	LPV415.99.30001
- with 15-m-cable	LPV415.99.40001
- with 20-m-cable	LPV415.99.50001
- with 30-m-cable	LPV415.99.60001
- with 50-m-cable	LPV415.99.70001
ACCESSORIES	
CVM verification / calibration module (dry standard)	
- approx. 0,6 FNU	LZV414.00.0000
- approx. 1.5 FNU	LZV414.00.1000
- approx. 6 FNU	LZV414.00.2000
- approx. 15 FNU	LZV414.00.3000
- approx. 25 FNU	LZV414.00.4000
Formazine turbidity standard	LCW813
Turbidity calibration set for liquid standard	LZV451
Filter set for zero point calibration (0.2 µm membrane filter incl. connection material)	LZV325
0.2 µm membrane filter (not including accessories)	EXF014
SPARE PARTS AND CONSUMABLES	
Set of wiper profiles for 4 changes	LZV275

DR. BRUNO LANGE
GMBH & CO. KG
Willstätterstraße 11
D-40549 Düsseldorf
Tel. +49 (0)2 11 52 88-0
Fax +49 (0)2 11 52 88-143
info@hach-lange.de
www.hach-lange.com

HACH LANGE LTD
Lennox Road
Basingstoke
Hampshire, RG22 4AP
Tel. +44 (0)12 56 33 34 03
Fax +44 (0)12 56 33 07 24
info@hach-lange.co.uk
www.hach-lange.com

Hyxo Oy
P.O. Box 16 (Palokorvenkatu 2)
FI-04261 Kerava, Finland
Tel. +358 10 417 4500
Fax +358 10 417 4501
hyxo@hyxo.fi • www.hyxo.com

